

SERIES CLH

FOR AUTOMATIC BONDERS

Double Flat , Vertical Feed for Hughes, Palomar, Hesse & Knipps and F&K Delvotec Bonders

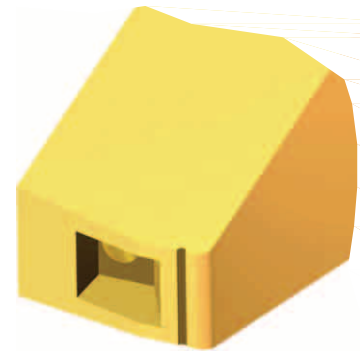
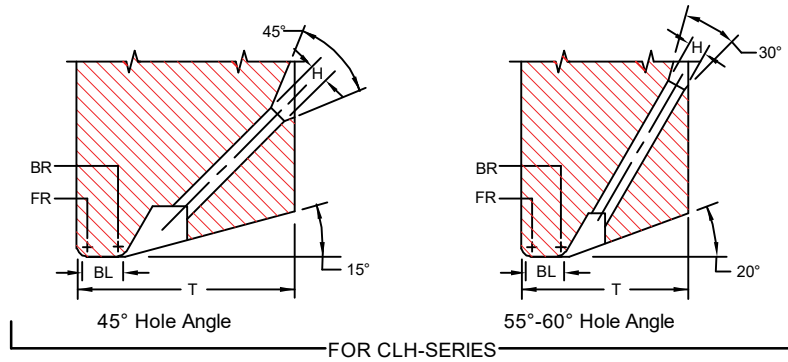

We recommend a .0005" back radius and a cross groove or a flat bond foot when ordering tools for gold wire thermosonic bonding. For more gold wire application information see **Tech Tips**

CLH-SERIES

WIRE Ø .0005" through .0020

S1 Option

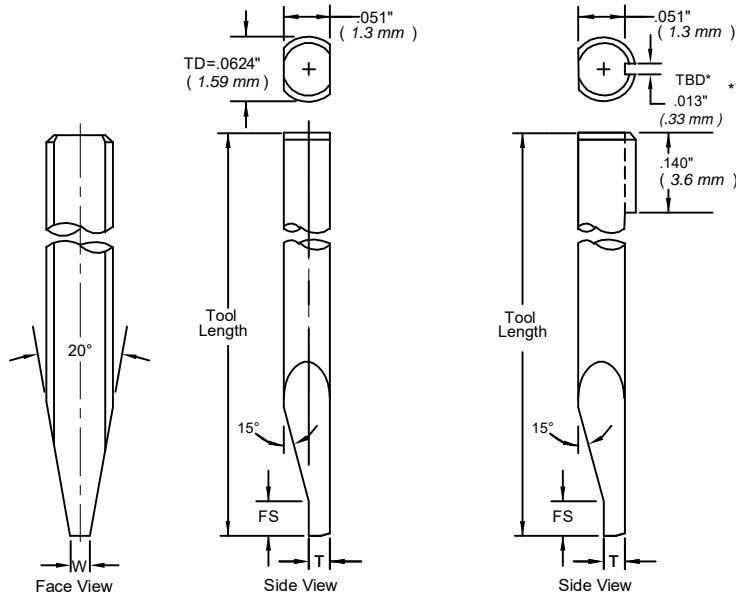

Standard: Ø 1/16, Hole Angle: 45°, 55°, 60°, FS"=.015" (.38 mm)

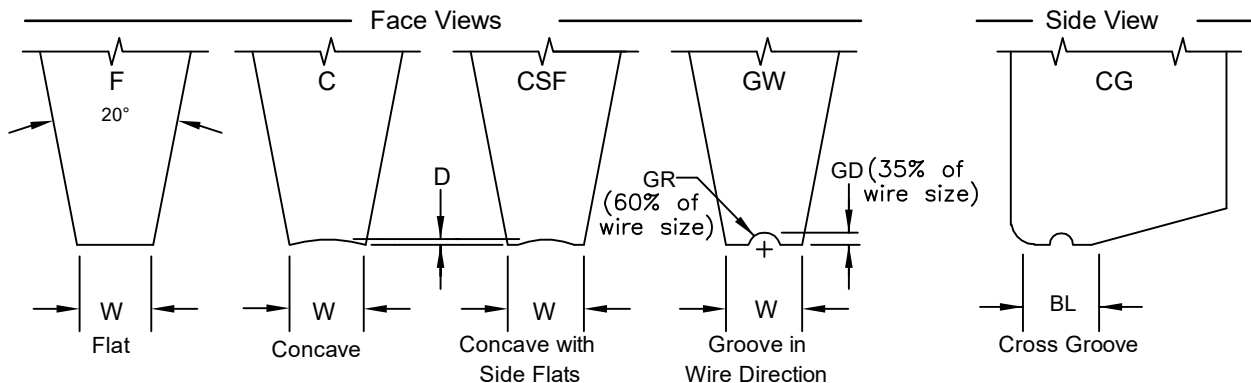

SERIES CLH

SMALL WIRE

ORDERING INFORMATION
SMALL WIRE BONDING WEDGES
FOR GOLD AND ALUMINUM WIRE

SAMPLE PART NUMBER: M-CLH-D-1/16-3/4-45-CG-2020-M-*

SYMBOL EXPLANATION: 1 2 3 4 5 6 7 8 9 10

1. MATERIAL: _____
 M = Ceramic
 C = Tungsten Carbide
 T = Titanium
 All other: See Material Selection Guide
 2. SERIES: CLH _____
 3. FRONT/BACK RADIUS: See Radius Option Chart _____
 *For special Radius sizes insert an X Please specify FR/BR
 4. SHANK DIA.: Please Specify Diameter _____
 5. TOOL LENGTH: Please Specify Length _____
 6. HOLE ANGLE: 45°,55°,60 _____
- (10) S1 and other Option
See Tool Options
- (9) FOOT FINISH:
M = Matte finish (FR, BR, & Bond Flat)
P = Polish finish (FR, BR, & Bond Flat)
MP = Polish finish (FR, BR), and Matte finish (Bond Flat)
- (8) TOOL SIZE: See Standard Chart
- (7) FOOT TYPE:
F = Flat
C = Concave
CSF = Concave with Side Flats (CSF not available with ceramic tools)
CG = Cross Groove
GW = Groove in wire direction (Please specify wire size)
- For special sizes or dimensions insert an (X) in the appropriate position of the part number then specify what (X) equals.
 Example: M-CLH-X-1/16-3/4-45-F-2020-M (X) FR=.0012, BR=.0007

RADIUS OPTION CHART	OPTION LETTER		A	B	C	D	E	F	G	H	I	J	K	L	M	N
	FRONT RADIUS	in.	.0005	.0005	.0010	.0010	.0010	.0015	.0015	.0015	.0015	.0020	.0020	.0020	.0020	.0020
		μ	13	13	25	25	25	38	38	38	38	51	51	51	51	51
BACK RADIUS	in.	0	.0005	0	.0005	.0010	0	.0005	.0010	.0015	0	.0005	.0010	.0015	.0020	
	μ	0	13	0	13	25	0	13	25	38	0	13	25	38	51	

STANDARD CHART														CLH SMALL WIRE:		FOR WIRE DIAMETERS .0005" THROUGH .0020"	
TS	H		BL		D		T 45°		T(55° 60°)		W		SUGGESTED WD				
Units	in.	μ	in.	μ	in.	μ	in.	μ	in.	μ	in.	μ	in.	μ			
Tolerance	±.0002	±5	±.0002	±5	-.0001	-2.5	±.0005	±13	±.0005	±13	±.0005	±13	±.0002	±5			
1505	.0015	38	.0005	13	.0002	5	.0090	229	.0075	191	.0025	64	.0005 through .0007	13 18			
1507	.0015	38	.0007	18	.0002	5	.0090	229	.0075	191	.0025	64					
1510	.0015	38	.0010	25	.0002	5	.0100	254	.0080	203	.0025	64					
1513	.0015	38	.0013	33	.0002	5	.0100	254	.0080	203	.0025	64					
1515	.0015	38	.0015	38	.0002	5	.0100	254	.0080	203	.0025	64					
1520	.0015	38	.0020	51	.0002	5	.0110	279	.0090	229	.0025	64					
Tolerance	±.0002	±5	±.0002	±5	-.0001	-2.5	±.0005	±13	±.0005	±13	±.0002	±5	.0007 through .0010	18 25			
2010	.0020	51	.0010	25	.0002	5	.0100	254	.0090	229	*.0040	102					
2015	.0020	51	.0015	38	.0002	5	.0110	279	.0100	254	.0040	102					
2020	.0020	51	.0020	51	.0002	5	.0110	279	.0100	254	.0040	102					
2025	.0020	51	.0025	64	.0002	5	.0120	305	.0110	279	.0040	102					
2030	.0020	51	.0030	76	.0002	5	.0120	305	.0110	279	.0040	102					
2520	.0025	64	.0020	51	.0002	5	.0130	330	.0110	279	.0040	102	.0013 33				
2525	.0025	64	.0025	64	.0002	5	.0130	330	.0120	305	.0040	102					
2530	.0025	64	.0030	76	.0002	5	.0140	356	.0120	305	.0050	127					
2535	.0025	64	.0035	89	.0002	5	.0140	356	.0130	330	.0050	127					
2540	.0025	64	.0040	102	.0002	5	.0150	381	.0130	330	.0050	127					
3020	.0030	76	.0020	51	.0003	8	.0140	356	.0120	305	.0050	127					
3025	.0030	76	.0025	64	.0003	8	.0140	356	.0130	330	.0050	127	.0015 38				
3030	.0030	76	.0030	76	.0003	8	.0150	381	.0130	330	.0050	127					
3035	.0030	76	.0035	89	.0003	8	.0150	381	.0140	356	.0050	127					
3040	.0030	76	.0040	102	.0003	8	.0160	406	.0140	356	.0050	127					
3525	.0035	89	.0025	64	.0003	8	.0150	381	.0130	330	.0060	152					
3530	.0035	89	.0030	76	.0003	8	.0150	381	.0130	330	.0060	152					
3535	.0035	89	.0035	89	.0003	8	.0160	406	.0140	356	.0060	152	.0020 51				
3540	.0035	89	.0040	102	.0003	8	.0160	406	.0140	356	.0060	152					
3545	.0035	89	.0045	114	.0003	8	.0170	432	.0150	381	.0060	152					
3550	.0035	89	.0050	127	.0003	8	.0170	432	.0150	381	.0060	152					

*Other sizes available upon request *All dimensions and tolerances are for reference only
 TOOL SIZE=TS, WIRE DIAMETER=WD, "T" To be determined according to the size of FR and BR and Hole Bore Length