

# SERIES AN & AN-V

SMALL WIRE & LARGE WIRE

FOR AUTOMATIC BONDERS

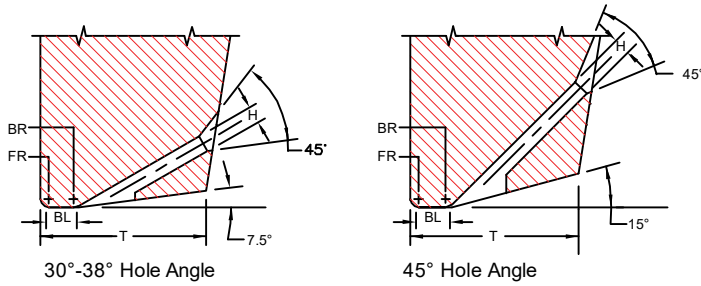

FOR AN-V SERIES (VERTICAL FEED)

FOR AN SERIES



Available Vertical Hole Ø marked with X

	TD		TDF		For Vertical Hole
	in.	mm	in.	mm	
1/16	.0624	1.59	.0460	1.17	
1/16	.0624	1.59	.0590	1.50	X
	.0784	1.99	.0630	1.60	
	.0784	1.99	.0720	1.83	X
3/32	.0937	2.38	.0880	2.24	X
	.1180	3.00	.0985	2.50	
1/8	.1249	3.17	.0937	2.38	
1/8	.1249	3.17	.1180	3.00	

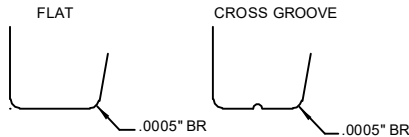

We recommend a .0005" back radius and a cross groove or a flat bond foot when ordering tools for gold wire thermosonic bonding. For more gold wire application information see Tech Tip

## AN-SERIES SMALL WIRE

.0005" through .0020" wireØ

## AN-SERIES LARGE WIRE

For wire diameters .0030" through .0160"

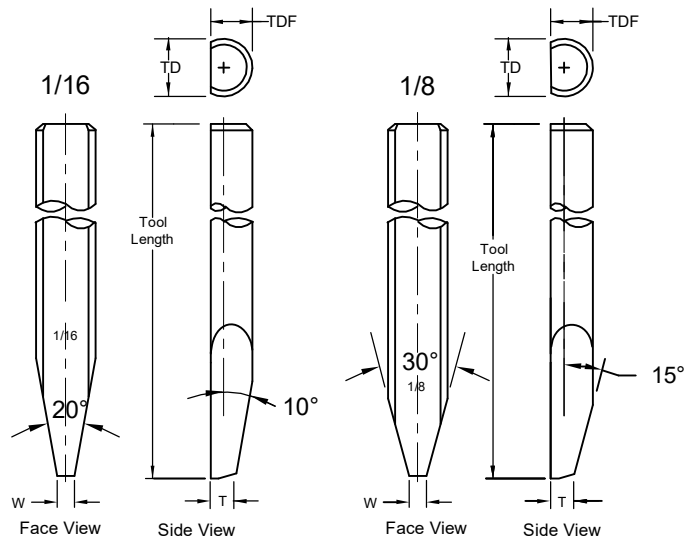

Standard: Ø 1/16, 45° Hole Angle

## AN-V SERIES VERTICAL FEED DEEP ACCESS

.0005" through .0020" wireØ

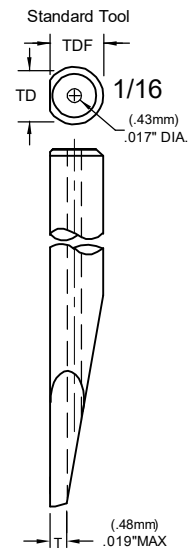

Standard: Ø 1/16 45° Hole Angle

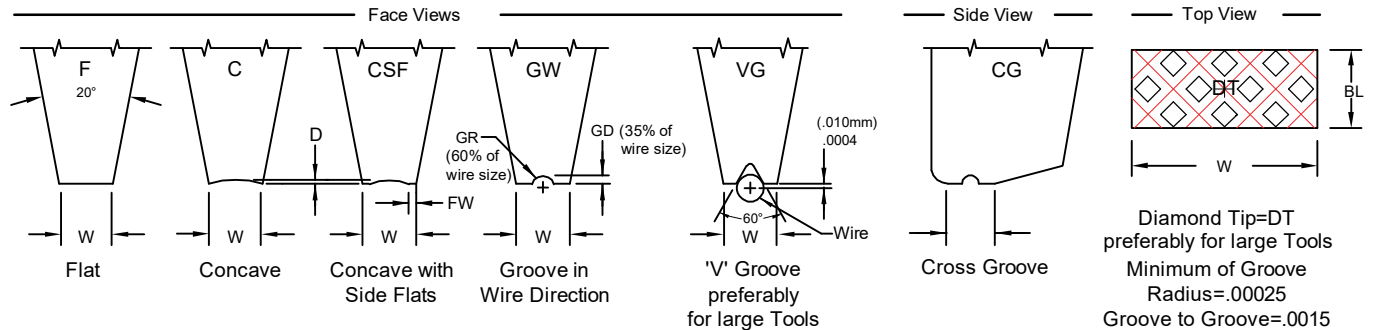

# SERIES AN & AN-V

## SMALL WIRE & LARGE WIRE

ORDERING INFORMATION  
SMALL & LARGE WIRE BONDING WEDGES  
FOR GOLD AND ALUMINUM WIRE

SAMPLE PART NUMBER: **M-AN-O-X-1/16-1-45-CG-2020-M-\***

SYMBOL EXPLANATION: 1 2 3 4 5 6 7 8 9 10 11

- MATERIAL:**
  - M = Ceramic
  - C = Tungsten Carbide
  - T = Titanium
  - All other: See Material Selection Guide
- SERIES:** AN
- WIRE FEED:** O = Standard Feed  
V = Vertical Feed
- FRONT/BACK RADIUS:** See Radius Option Chart  
\*For special Radius sizes insert an X Please specify FR/BR
- SHANK DIA.:** Please Specify Diameter
- TOOL LENGTH:** Please Specify Length
- HOLE ANGLE:** for AN (30°, 38°, 45°)  
for AN-V (45°)

(11) See Tool Option

(10) FOOT FINISH:

M = Matte finish (FR, BR, & Bond Flat)  
P = Polish finish (FR, BR, & Bond Flat)  
MP = Polish finish (FR, BR), and  
Matte finish (Bond Flat)

(9) TOOL SIZE: See Standard Chart

(8) FOOT TYPE:

F = Flat  
C = Concave  
CSF = Concave with Side Flats  
(CSF not available with ceramic tools)  
CG = Cross Groove  
GW = Groove in wire direction  
(Please specify wire size)  
DT = Diamond Tip (Please specify Ribbon size)  
VG = V Groove (Please specify wire size)

\*NOTE: Please specify for either guillotine cut or tension break.  
On V-groove tools the bond length (BL) is the same as the foot length (FL).  
For special sizes or dimensions insert an (X) in the appropriate position of the part number  
then specify what (X) equals.  
Example: M-AN-O-X-1/16-3/4-45-CG-2020-M (X) FR=.0012, BR=.0007

RADIUS OPTION CHART	OPTION LETTER		A	B	C	D	E	F	G	H	I	J	K	L	M	N	
	FRONT RADIUS	in.	.0005	.0005	.0010	.0010	.0010	.0015	.0015	.0015	.0015	.0015	.0020	.0020	.0020	.0020	.0020
	BACK RADIUS	μ	13	13	25	25	25	38	38	38	38	38	51	51	51	51	51
		in.	0	.0005	0	.0005	.0010	0	.0005	.0010	.0015	0	.0005	.0010	.0015	.0020	
		μ	0	13	0	13	25	0	13	25	38	0	13	25	38	51	

For Vertical Feed: Tmax. for Dia. 1/16 = .0190 and for A8D: Tmax=.0243, Supplies only to Standard size Ø1/16, larger tool Ø are different.

STANDARD CHART		AN SMALL WIRE:		FOR WIRE DIAMETERS .0005" THROUGH .0020"										SUGGESTED WD	
TS	H	BL	D	T(30°38°)		T(45°)		W							
Units	in. μ	in. μ	in. μ	in. μ	in. μ	in. μ	in. μ	in. μ	in. μ	in. μ	in. μ	in. μ	in. μ		
Tolerance	±.0002 ±5	±.0002 ±5	-.0001 -2.5	±.0005 ±13	±.0005 ±13	±.0005 ±13	±.0005 ±13	±.0005 ±13	±.0005 ±13	±.0005 ±13	±.0005 ±13	±.0005 ±13	±.0005 ±13		
1505	.0015 38	.0005 13	.0002 5	.0140 356	.0110 279	.0025 64									
1507	.0015 38	.0007 18	.0002 5	.0140 356	.0110 279	.0025 64									
1510	.0015 38	.0010 25	.0002 5	.0140 356	.0120 305	.0025 64									
1513	.0015 38	.0013 33	.0002 5	.0140 356	.0120 305	.0025 64									
1515	.0015 38	.0015 38	.0002 5	.0150 381	.0120 305	.0025 64									
1520	.0015 38	.0020 51	.0002 5	.0150 381	.0130 330	.0025 64									
Tolerance	±.0002 ±5	±.0002 ±5	-.0001 -2.5	0.0005 12.7	±.0005 ±13	±.0002 ±5									
2010	.0020 51	.0010 25	.0002 5	.0160 406	.0120 305	*.0040 102									
2015	.0020 51	.0015 38	.0002 5	.0160 406	.0130 330	.0040 102									
2020	.0020 51	.0020 51	.0002 5	.0170 432	.0140 356	.0040 102									
2025	.0020 51	.0025 64	.0002 5	.0170 432	.0140 356	.0040 102									
2030	.0020 51	.0030 76	.0002 5	.0170 432	.0150 381	.0040 102									
2520	.0025 64	.0020 51	.0002 5	.0170 432	.0150 381	.0040 102									
2525	.0025 64	.0025 64	.0002 5	.0170 432	.0160 406	.0040 102									
2530	.0025 64	.0030 76	.0002 5	.0180 457	.0160 406	.0050 127									
2535	.0025 64	.0035 89	.0002 5	.0180 457	.0170 432	.0050 127									
2540	.0025 64	.0040 102	.0002 5	.0180 457	.0170 432	.0050 127									
3020	.0030 76	.0020 51	.0003 8	.0180 457	.0170 432	.0050 127									
3025	.0030 76	.0025 64	.0003 8	.0200 508	.0170 432	.0050 127									
3030	.0030 76	.0030 76	.0003 8	.0200 508	.0180 457	.0050 127									
3035	.0030 76	.0035 89	.0003 8	.0210 533	.0180 457	.0050 127									
3040	.0030 76	.0040 102	.0003 8	.0210 533	.0180 457	.0050 127									
3525	.0035 89	.0025 64	.0003 8	.0220 559	.0190 483	.0060 152									
3530	.0035 89	.0030 76	.0003 8	.0220 559	.0200 508	.0060 152									
3535	.0035 89	.0035 89	.0003 8	.0230 584	.0200 508	.0060 152									
3540	.0035 89	.0040 102	.0003 8	.0230 584	.0210 533	.0060 152									
3545	.0035 89	.0045 114	.0003 8	.0240 610	.0210 533	.0060 152									
3550	.0035 89	.0050 127	.0003 8	.0240 610	.0210 533	.0060 152									

STANDARD CHART		AN LARGE WIRE:		FOR WIRE DIAMETERS .0030" THROUGH .0160"										SUGGESTED WD	
TS	H	BL	D	T(30°38°)		T(45°)		W							
Units	in. μ	in. μ	in. μ	in. μ	in. μ	in. μ	in. μ	in. μ	in. μ	in. μ	in. μ	in. μ	in. μ		
Tolerance	±.0005 ±13	±.0005 ±13	-.0001 -2.5	±.0010 ±25	±.0010 ±25	±.0010 ±25	±.0010 ±25	±.0010 ±25	±.0010 ±25	±.0010 ±25	±.0010 ±25	±.0010 ±25	±.0010 ±25		
4560	.0045 114	.0060 152	.0006 15	.0340 864	.0310 787	.0075 191									
6008	.0060 152	.0080 203	.0008 20	.0390 991	.0340 864	.0100 254									
7510	.0075 191	.0100 254	.0010 25	.0450 1143	.0410 1041	.0125 318									
0912	.0090 229	.0120 305	.0012 30	.0520 1321	.0490 1245	.0150 381									
Tolerance	±.0005 ±13	±.0010 ±25	±.0002 ±5	±.0010 ±25	±.0010 ±25	±.0010 ±25									
01014	.0105 267	.0140 356	.0014 36	.0650 1651	.0540 1372	.0175 445									
01215	.0120 305	.0150 381	.0016 41	.0680 1727	.0560 1422	.0200 508									
01518	.0150 381	.0180 457	.0020 51	.0720 1829	.0640 1626	.0250 635									
01820	.0180 457	.0200 508	.0024 61	.0900 2286	.0800 2032	.0300 762									
02122	.0210 533	.0220 559	.0028 71	.0980 2489	.0820 2083	.0350 889									
02424	.0240 610	.0240 610	.0032 81	.1100 2794	.0930 2362	.0400 1016									

\*Other sizes available upon request \*All dimensions and tolerances are for reference only  
TOOL SIZE=TS, WIRE DIAMETER =WD, "T" To be determined according to the size of FR and BR and Hole Bore Length