

SERIES RKNH

Double Flat, Vertical Feed for
Hughes, Palomar, Hesse & Knipps and F&K Delvotec Bonders

FOR AUTOMATIC BONDERS

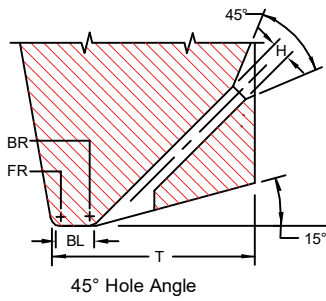

45° Hole Angle

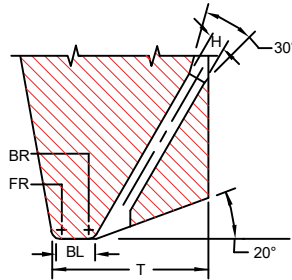

55°-60° Hole Angle

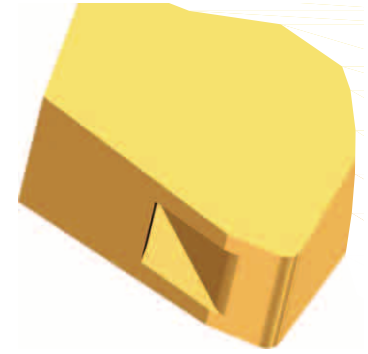

FOR RKNH-SERIES

FLAT

CROSS GROOVE



We recommend a .0005" back radius and a cross groove or a flat bond foot when ordering tools for gold wire thermosonic bonding. For more gold wire application information see **Tech Tip**

RKNH-SERIES RIBBON WIRE

Ribbon Width: .0020" through .0200"

Ribbon Thickness: .00025" through .0020"

* S1 Option

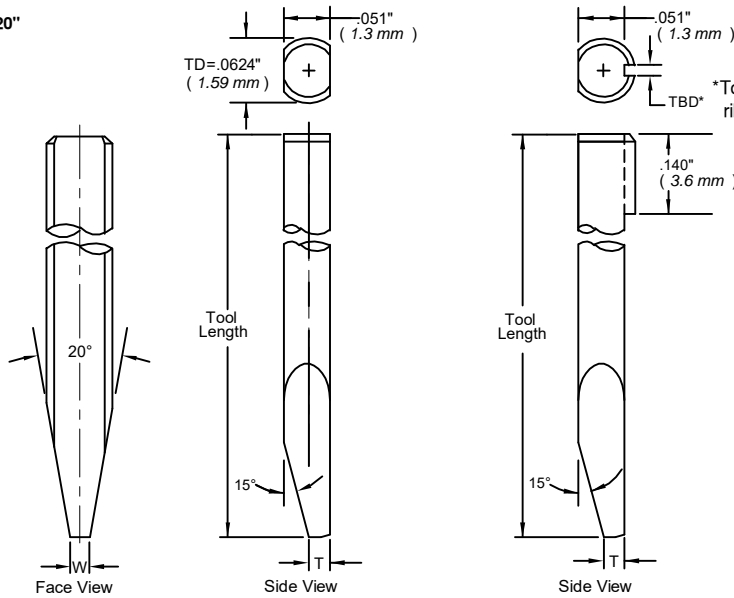

*To be determined according to ribbon size

Standard: Ø 1/16, 45°, 55°, 60° Hole Angle

Side View

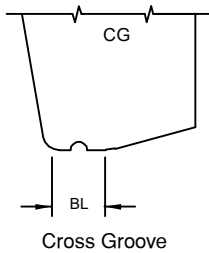

Cross Groove

F

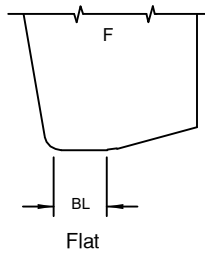

Flat

Back View

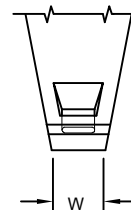

W

Top View

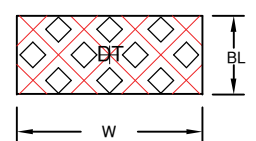

Diamond Tip=DT preferably for large Tools
Minimum of Groove Radius=.00025
Groove to Groove=.0015

SERIES RKNH

RIBBON WIRE

ORDERING INFORMATION

RIBBON BONDING WEDGES

FOR GOLD AND ALUMINUM WIRE

SAMPLE PART NUMBER: M-RKNH-D-1/16-1"-45-CG-.5x5-2-M-*

SYMBOL EXPLANATION: 1 2 3 4 5 6 7 8 9 10 11

1. **MATERIAL:**
 - M = Ceramic
 - C = Tungsten Carbide
 - T = Titanium
 - All other: See Material Selection Guide
2. **SERIES:** RKNH
3. **FRONT/BACK RADIUS:** See Radius Option Chart
 *For special Radius sizes insert an X Please specify FR/BR
4. **SHANK DIA.:** Please Specify Diameter
5. **TOOL LENGTH:** Please Specify Length
6. **HOLE ANGLE:** for RKNH (45°,55°,60°)
- (11) See Tool Option
- (10) **FOOT FINISH:**
 - M = Matte finish (FR, BR, & Bond Flat)
 - P = Polish finish (FR, BR, & Bond Flat)
 - MP = Polish finish (FR, BR), and Matte finish (Bond Flat)
- (9) **Bond Length:** See Standard Chart
 Example: BL of .0020 = 2
 Note: We do not recommend bond lengths any larger than .005".
- (8) **RIBBON SIZE:** See Standard Chart
 Example: .0005 x .005 = .5 x 5
 Thickness x Width
- (7) **FOOT TYPE:**
 - F = Flat
 - CG = Cross Groove
 - DT = Diamond Tip
 (Please specify Ribbon size)

For special sizes or dimensions insert an (X) in the appropriate position of the part number then specify what (X) equals. Example: M-RKNH-X-1/16-1"-45-CG-.5x5-2-M-A7 (X) FR=.0012, BR=.0007

RADIUS OPTION CHART	OPTION LETTER		A	B	C	D	E	F	G	H	I	J	K	L	M	N
	FRONT RADIUS	in.	μ	.0005 13	.0005 13	.0010 25	.0010 25	.0010 25	.0015 38	.0015 38	.0015 38	.0015 38	.0020 51	.0020 51	.0020 51	.0020 51
BACK RADIUS	in.	μ	0	.0005 13	0	.0005 13	.0010 25	0	.0005 13	.0010 25	.0015 38	0	.0005 13	.0010 25	.0015 38	.0020 51

STANDARD CHART		RKNH		FOR RIBBON THICKNESS: .00025" THROUGH .0020"									
RIBBON WIDTH		RIBBON THICKNESS		BL		T(45°)		T(55° 60°)		W			
in.	μ	in.	μ	in.	μ	in.	μ	in.	μ	in.	μ	in.	μ
Tolerance				±.0002	±5	±.0005	±13	±.0005	±13	±.0002	±5		
.0020	51	.00025 through .00125	6.4 32	.0010	25	.0090	229	.0080	203	.0055	140		
				.0015	38	.0100	254	.0080	203				
				.0020	51	.0110	279	.0090	229				
				.0025	64	.0115	292	.0100	254				
.0030	76	.00025 through .00125	6.4 32	.0010	25	.0090	229	.0080	203	.0065	165		
				.0015	38	.0100	254	.0080	203				
				.0020	51	.0110	279	.0090	229				
				.0025	64	.0115	292	.0100	254				
.0040	102	.00025 through .00125	6.4 32	.0020	51	.0110	279	.0090	229	.0075	191		
				.0025	64	.0115	292	.0100	254				
				.0030	76	.0115	292	.0100	254				
				.0035	89	.0120	305	.0100	254				
.0050	127	.0005 through .0020	13 51	.0025	64	.0120	305	.0100	254	.0085	216		
				.0030	76	.0120	305	.0100	254				
				.0035	89	.0125	318	.0110	279				
				.0040	102	.0125	318	.0110	279				
.0070	178	.0005 through .0020	13 51	.0025	64	.0120	305	.0100	254	.0125	318		
				.0030	76	.0120	305	.0100	254				
				.0035	89	.0125	318	.0110	279				
				.0040	102	.0125	318	.0110	279				
.0100	254	.0005 through .0020	13 51	.0025	64	.0120	305	.0100	254	.0155	394		
				.0030	76	.0120	305	.0100	254				
				.0035	89	.0125	318	.0110	279				
				.0040	102	.0125	318	.0110	279				
.0120	305	.0005 through .0020	13 51	.0025	64	.0120	305	.0100	254	.0175	445		
				.0030	76	.0120	305	.0100	254				
				.0035	89	.0125	318	.0110	279				
				.0040	102	.0125	318	.0110	279				
.0150	381	.0005 through .0020	13 51	.0025	64	.0120	305	.0100	254	.0205	521		
				.0030	76	.0120	305	.0100	254				
				.0035	89	.0125	318	.0110	279				
				.0040	102	.0125	318	.0110	279				
.0200	508	.0005 through .0020	13 51	.0025	64	.0120	305	.0100	254	.0255	648		
				.0030	76	.0120	305	.0100	254				
				.0035	89	.0125	318	.0110	279				
				.0040	102	.0125	318	.0110	279				

*Other sizes available upon request *All dimensions and tolerances are for reference only
 "T" To be determined according to the size of FR and BR and Hole Bore Length